



**Trolley basic information:**

product model	Trolley
Product load bearing	7.5 KG-18 KG after the counterweight
angle of pitch	unadjustable
angle of rotation	360°
Cart size	580*580*1130cm
Lift height	740-1130mm
Lift way	Mechanical lift-aerable spring lift
material quality	Aluminum alloy-surface anodized, sheet metal-powder spraying

**technical parameter:**

	Dimensions: 3 inches-7.3cm
	Material: PU-gray + white
	Function: universal silent wheel, double-sided anti-winding
	Configuration: 2 brake, 3 no brake

	Dimensions: φ580mm
	Material: sheet metal
	Process: powder spraying-medical white
	Weight: 1.7 KG-plus counterweight 5 KG

	Dimensions: φ 50mm, L=510mm
	Material: aluminum alloy
	Process: surface anodizing-silver

	Dimensions: φ 25mm, L=500mm
	Material: stainless steel
	Technology: polishing the natural color-bright color

way to install	The bottom of the machine is screws and the back
packing measurement	78*63*21.5cm
rough weight	9KG
attestation	ISO9001/ISO13485/TUV CE/ROSH/FDA

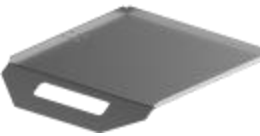

	Dimensions: 330 * 210 * 130mm
	Material: environmental iron
	Technology: baking paint-medical white

	Dimensions: inner space 420 * 400 outer diameter 426 * 500
	Material: aluminum alloy
	Process: surface anodizing-silver
	Fencing height: 10mm

	Dimensions: upper hole-60mm, lower hole-hole 1:20mm hole 2:32mm
	Depth: 60mm
	material quality:ABS
	Technology: Color gray